

MODEL TCF-S

TEMPERATURE COMPENSATING FOCUSER

U.S. Patent No. 6,327,081

TECHNICAL MANUAL FOR
THEORY OF OPERATION AND OPERATING PROCEDURES

 ***OPTEC, Inc.***

OPTICAL AND ELECTRONIC PRODUCTS

info@optecinc.com
<http://www.optecinc.com>

199 Smith St.
Lowell, MI 49331
U.S.A.
(888) 488-0381 Toll-Free
(616) 897-9351
(616) 897-8229 FAX



Figure 1-1. Model TCF-S and TCF-S3 Temperature Compensating Focuser.

TABLE OF CONTENTS

January 2006

<i>Section</i>		<i>Page</i>
1.0	Introduction	1
2.0	Installation	2
3.0	Theory of Operation	4
3.1	Crayford Style Focuser	4
3.2	Focus Controller	5
4.0	Operating Procedures	8
4.1	Start-Up - Manual Mode	9
4.2	Start-Up - Auto Mode	9
4.3	Manual Focus Operation	10
4.4	Auto Focus Operation	11
4.5	Learn Operation	12
4.6	Shutdown	13
5.0	PC Software Control	14
5.1	TTL Level Control	14
5.2	Advanced TTL Control for the TCF	14
5.3	TCF-S RS-232 Serial Communications	15
	5.3.1 Connecting the TCF-S to the PC	15
	5.3.2 Communications Protocol	16
	5.3.3 TCF-S Commands	17
6.0	Troubleshooting	25
7.0	Specifications	27
 <i>Appendices</i>		
A	Wiring Diagram	A-1
B	Controller Board Layout	B-1
	Original TCF Hand Controller Circuit Board Layout	B-2
	TCF-S Hand Controller Circuit Board Layout	B-3
C	Circuit Diagram	C-1
D	TCF-S Control Using CCDSoft Version 5	D-1
E	TCF-S/TCF-S3 Controller Programs	E-1
F	Remote Keypad	F-1

LIST OF FIGURES

<i>Figure</i>		<i>Page</i>
1-1	Photograph of the TCF-S	Cover
2-1	TCF-S Focuser System Components	2
2-2	Items Included with TCF-S Focusers	3
3-1	TCF-S Cross-Sectional View with Part Descriptions	4
3-2	TCF-S Focuser Function Diagram	6
4-1	TCF-S Hand Control Layout	8

LIST OF TABLES

<i>Table</i>		<i>Page</i>
4-1	Start-Up (Manual Mode)	9
4-2	Start-Up (Auto Mode)	9
4-3	Manual Focus Operation	10
4-4	Auto Focus Operation	11
4-5	Learn Operation	12
4-6	Shutdown	13
5-1	Focuser Manual Mode Command	17
5-2	Focuser A Mode Command	17
5-3	Focuser B Mode Command	18
5-4	Focuser In Command	18
5-5	Focuser Out Command	19
5-6	Position Read-Out Command	19
5-7	Temperature Read-Out Command	20
5-8	Focuser Center Command	20
5-9	Focuser Sleep Command	21
5-10	Focuser Wake-up Command	21
5-11	Focuser Read Command	22
5-12	Focuser Load Command	22
5-13	Focuser Quiet Command	22
5-14	Focuser Delay Command	23
5-15	Focuser Home Command	23
5-16	Focuser Free Mode Command	24
5-17	Focuser Read Slope Sign Command	24
5-18	Focuser Load Slope Sign Command	24

SECTION 1.0

INTRODUCTION

Mechanically, the TCF-S 2-inch (Temperature Compensating Focuser) and new TCF-S3 3-inch is a robust Crayford style motorized focuser with high repeatability. The Crayford design allows for a solid friction roller focusing system with no play and very little backlash. Optec's implementation is ideal for applications that require exact focus such as for CCD imaging or film astrophotography. A geared stepper motor rotates the drive shaft with one step rotation of the motor equal to a 0.00008-inch for the TCF-S or 0.0001-inch for the TCF-S3 movement of the drawtube. A pair of pushbuttons control the direction of focus and the DRO (digital read-out) displays the current position. The TCF-S and TCF-S3 focuser can handle cameras and instrument packages weighing up to 10 and 20 pounds respectively.

Unique to the TCF-S/TCF-S3 focuser, an electronic controller system monitors the telescope's tube temperature and compensates the focus accordingly. A small temperature probe is attached to the side of the telescope tube and monitors temperature with a resolution of 0.1°C. For a typical Schmidt-Cassegrain of 8 to 11 inches aperture and f/10 focal ratio, the back focus will move approximately 0.20 mm for every 1°C change in telescope's temperature. It is not unusual during an observing session for the ambient temperature to change by as much as 10°C within the time span of a few hours. This change in focus due to temperature is a serious problem for most telescope designs and requires frequent re-focusing during long exposures. A typical RGB exposure sequence can last one hour making it imperative that the focus be checked and corrected after each filter change.

A simple learning procedure is used to find the temperature coefficients specific to the user's telescope system. The TCF-S/TCF-S3 system allows for two different coefficients (corresponding to two different f-ratio configurations) to be calculated and stored in the EEPROM memory. Once learned, either coefficient can be selected with a simple slide switch. A manual mode allows the user to set the focus manually at any time.

The digital nature of the TCF-S/TCF-S3 allows opportunities for truly intelligent focusing. Using a serial interface, a programmer can control the focuser from any PC. Exact focus can be found by optimizing a stellar centroid's diameter. Many popular camera control programs are compatible with the TCF-S/TCF-S3 including: CCDSoft, Maxim DL, FocusMAX, CCD Autopilot, ACP and CCD Commander.

At the end of an observing session, the TCF-S/TCF-S3 focuser remembers the last temperature and position. When the unit is turned back on for a new session, the TCF-S/TCF-S3 computes a new position using the current tube temperature and moves to that position. Assuming no changes to the optical configuration, the object will snap into sharp focus.

SECTION 2.0

INSTALLATION

Attach telescope adapter to telescope securely without the TCF-S/TCF-S3 focuser connected. Back out the three #8 setscrews (#10 setscrews for the TCF-S3) around the large diameter so that the TCF-S focuser can slip onto the telescope adapter. After rotating the TCF-S/TCF-S3 to the proper position, tighten the three setscrews evenly making sure no gap is visible between the TCF-S/TCF-S3 and the telescope adapter.

If the IFW filter wheel or MAXfilter is used, that item should be attached to the telescope first. An adapter is available to attach the TCF-S to the IFW or MAXfilter 2”.



Figure 2-1. TCF-S Focuser System Components.

Peel the paper backing off the foam square and use it to secure the temperature probe to the middle of the telescope tube. Place the temperature probe between the telescope tube and the foam square. The standard probe length is 20 inches that should accommodate Schmidt-

Cassegrain telescopes from 8 to 12 inches in aperture. Any special length up to 6 feet can be ordered from Optec. The connector tip used on the probe is a mini stereo plug. Connect the temperature probe plug into the stereo jack on the side of the motor housing.

A control cable with 8-pin modular connector on one end and a 9-pin sub-D connector on the other is used to connect the TCF-S/TCF-S3 focuser to the control box. Lengths of cable 6, 12, 25 and 50 feet long are available from Optec. This is the same cable used with the MAXfilter/IFW and can be interchanged. IMPORTANT NOTE: Accidentally switching controllers from the TCF and the MAXfilter/IFW will NOT cause any damage to either unit.

The power supply for the TCF-S/TCF-S3 is regulated at 12 VDC and 1.0 amp. Use only this type to power the TCF-S/TCF-S3 controller. The MAXfilter controller uses a 200 ma power supply that will overheat when used with the TCF-S/TCF-S3. When turning the power off to the TCF-S/TCF-S3 focuser controller, use the slide switch first. If the power connector is pulled or power is somehow interrupted to the unit, the current position and temperature will not be stored. When the unit is powered up again, the user will have to find a new focus manually.



Figure 2-2. Items Included with TCF-S or TCF-S3

SECTION 3.0

THEORY OF OPERATION

3.1 CRAYFORD STYLE FOCUSER

The TCF-S focuser uses a classical Crayford design with a 2-inch ID drawtube. Similarly, the TCF-S3 has a 3-inch drawtube. The drawtube is supported within a sturdy cylinder by four ball bearing rollers and a steel drive shaft mounted 120° apart. With a force of 100 to 200 pounds, the drive shaft pushes the drawtube against the ball bearing rollers, which eliminates all lateral play. Rotating the drive shaft moves the drawtube through a total distance of 0.6-inch for the TCF-S and 1.0-inch for the TCF-S3. The drive shaft for the TCF-S is supported by bearings and is made from 303 stainless steel ground to the finished diameter of 0.2497-inch. Because of the extra load capacity, the TCF-S3 uses a hardened high speed steel shaft of 0.3497-inch diameter.

The stepper motor with a 50:1 gearhead has a 0.1875-inch diameter drive shaft to which a 25-tooth spur gear is attached. The main drive shaft of the TCF-S is attached to a 96-tooth (quality 10) drive gear. In a similar fashion, the drive shaft of the TCF-S3 is attached to a 120 tooth gear. Thus, the total gear reduction from stepper motor to drive shaft is 192:1 for the TCF-S and 240:1 for the TCF-S3. Each step from the motor moves the drawtube 0.000085-inch for the TCF-S and, because of the larger drive shaft, 0.0001-inch for the TCF-S3. Total backlash of all the gears gives an approximate longitudinal play of 0.0015-inch (18 steps) as measured with an indicator.

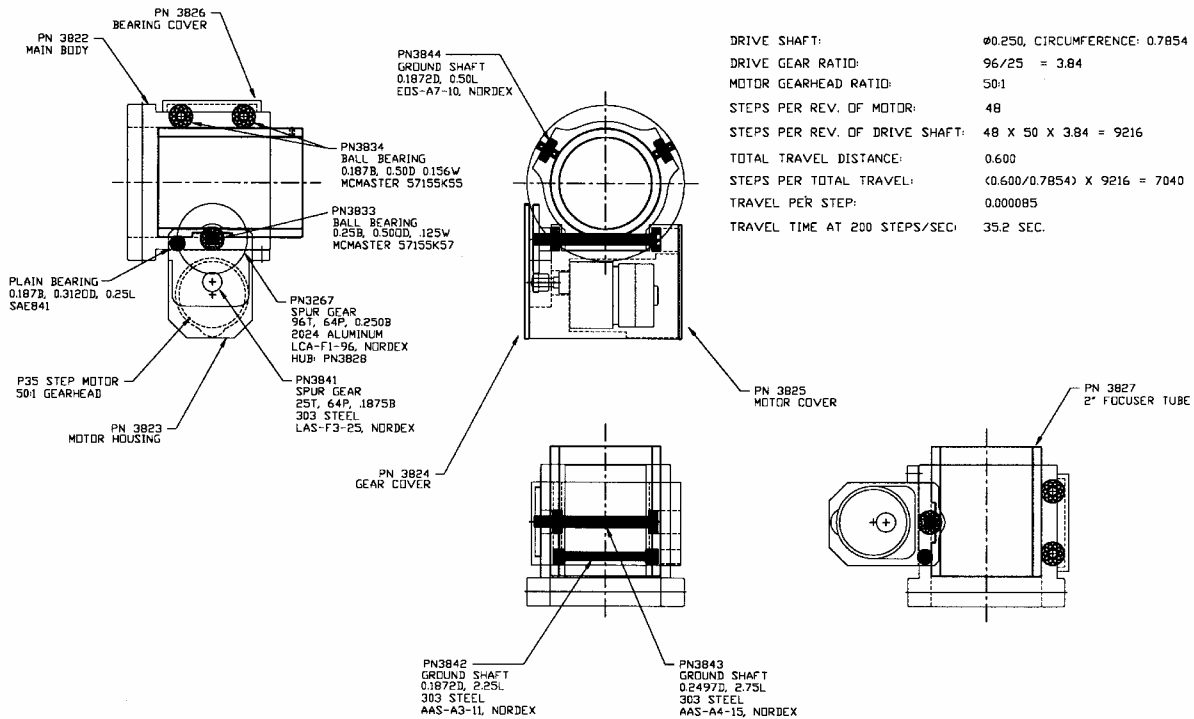

Figure 3-1. TCF-S Cross-Sectional View with Part Descriptions.

The motor and drive gears are protected in a motor housing with covers to eliminate any possible damage to the gear teeth. Drive shaft and stepper motor are all mounted in one machined part to make sure of the proper gear alignment and maintain rigidity with all loads. The rear of the motor housing has a 0.1875 diameter ground stainless steel shaft that connects it to the main body and also allows a small amount of rotation. On the other side of the housing, two #6 cap screws press the unit with drive shaft against the drawtube with considerable force.

A lightweight 6061 aluminum alloy is used for all machined parts with the exception of the drawtube. Because of its higher demand for strength and rigidity, the drawtube of the TCF-S is made from 6262-T9 alloy, which has almost twice the strength of 6061. In the case of the TCF-S3, the drawtube is made from 7075 alloy which has the most strength of all the common aluminum alloys. All aluminum parts are bright dip and black anodized for maximum corrosion protection. The drawtube is anodized with a “hard anodized coat” for increased durability.

See *Figure 3-1* for sectional views and part descriptions of the focuser assembly.

3.2 FOCUS CONTROLLER

The heart of the controller is the PIC programmable CMOS microcontroller made by Microchip. This device has 22 I/O pins, 8K of program memory, 192 bytes of RAM and operates at 8 MHz. Using CMOS technology, this device uses very little power and can operate within the industrial temperature range specification of -25°C to +80°C. All programming was done in basic and compiled using PIC Basic Pro by *microEngineering Labs* of Colorado Springs.

See *Figure 3-2* for a function diagram view of the TCF-S controller.

The input power source is from a switching DC power unit rated at 12 VDC regulated and 1.0 amp maximum output current. Normally, the TCF-S/TCF-S3 uses only 230-350 ma when operating. A three terminal regulator produces +5 VDC for use by the PIC microcontroller, EEPROM, DRO display and stepper motor controller chips. Using a variety of protection devices, the input power port is well protected from voltage surges, reverse voltage, low voltage (brownout) and other circuit busting conditions. A replaceable 5x20 mm fuse rated at 0.5 amps is used for final input protection. This fuse will blow if the input voltage is reversed which could only happen if the user incorporates a custom power source such as an automotive battery. At the time of this manual revision, a new controller board is in prototype development and it has a 0.5-amp polyswitch fuse that is resetable. This board will be used in all control boxes made after March 2006.

Power is supplied to the TCF-S controller circuits through an SPDT relay of which the coil is energized by both one pole of the power switch and one of the microcontroller output ports. Thus, when power is switched off, the microcontroller will sense this condition and will keep the relay coil energized until the shutdown procedure is completed. The shutdown procedure consists

mainly of writing the current temperature and position to the EEPROM chip, which takes about 0.3 seconds.

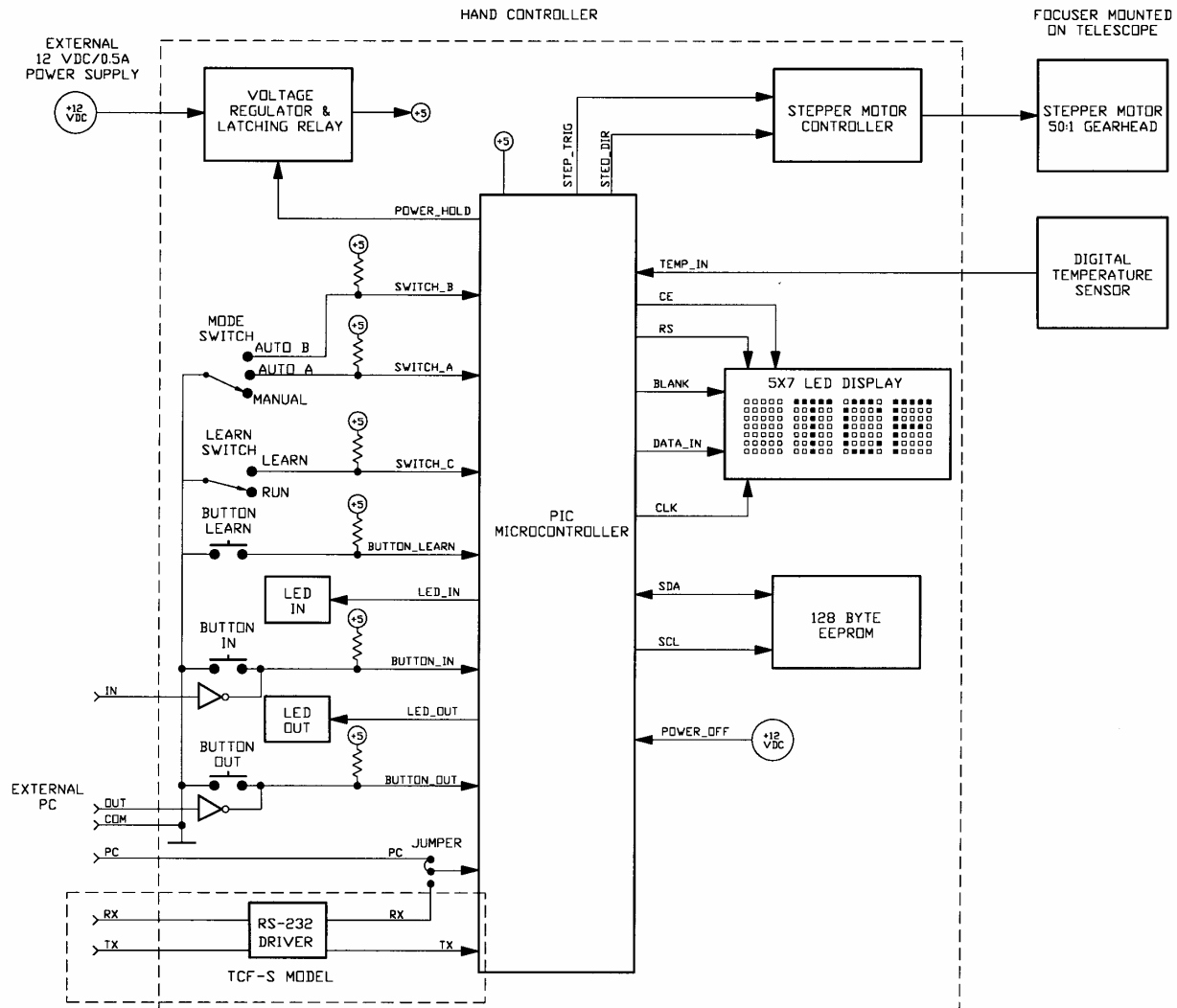

Figure 3-2. TCF-S/TCF-S3 Focuser Function Diagram.

An Analog Devices TMP04 serial digital output thermometer is used in the temperature probe. The modulated signal from this device is processed by the PIC microcontroller and reduced to a Centigrade scale with 0.1°C resolution. This digital device can operate over an extreme temperature range and, being digital, produces a very stable output which is unaffected by cable length and common noise sources.

The DRO uses a premium Hewlett Packard CMOS 5x7 matrix LED display showing four characters with a height of 0.15 inch. The selection of this device over a lower cost LCD unit is primarily based on performance. This unit can operate down to -40°C and the LED dot matrix

display is far more visible in low light conditions compared to a LCD device. In addition, the face of the display is protected by a piece of 1/16-inch thick red acrylic lens, which also enhances contrast.

When the drawtube has moved all the way IN focus toward the telescope, a zero (0) reading is shown on the DRO display. Movement of the drawtube in the opposite direction or OUT focus will stop at position 7000, which translates to a total travel distance of 0.60 inches.

An integrated BiMOS unipolar driver chip is used to operate the stepper motor. This device is rated to operate within the industrial temperature range of -20°C to +85°C and can output a maximum current of 1.5 Amps far exceeding the needs of the motor. This integrated circuit is fully protected against inductive transients. In addition, thermal protection circuitry will disable the outputs when the chip temperature is excessive. This could happen if the output cable is shorted because of damage or wear.

SECTION 4.0

OPERATING PROCEDURES

Refer to *Figure 4-1* for a view of the hand controller front panel. Tables 4-1 through 4-6 below explain the six most typical procedures of the TCF-S/TCF-S3. Switch settings, functions, and errors are described.

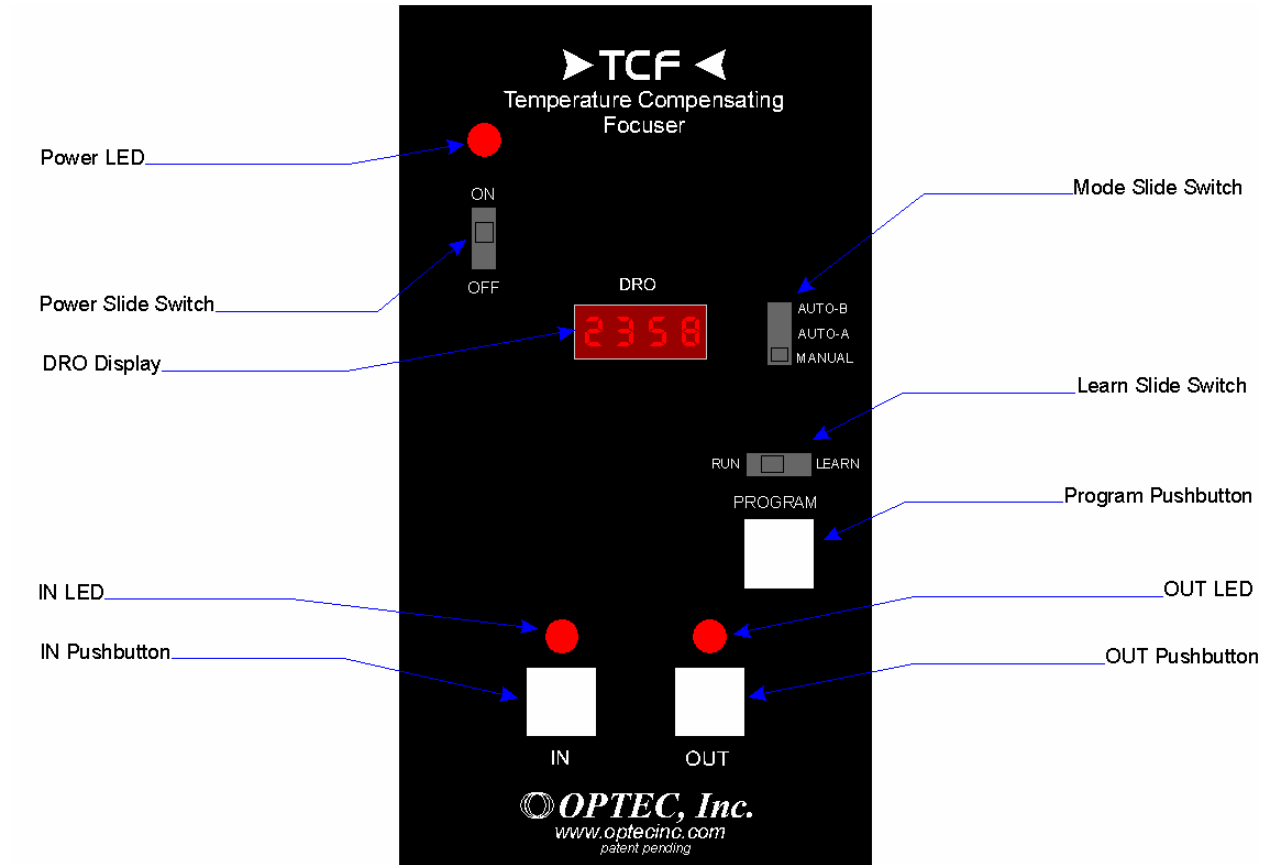

Figure 4-1. TCF-S/TCF-S3 Hand Control Layout.

START-UP (MANUAL MODE)
<p>SWITCH SETTINGS: Mode switch is in MANUAL position Learn switch is in RUN position</p>
<p>FUNCTION: At the start, the focuser will move all the way IN focus to position 0 (HOME). The DRO will alternately display the letters TCFS and version number. In addition, both LEDs above the IN/OUT pushbuttons will be lighted. When at home, the controller will read the last position before it was shutdown from the EEPROM. The focuser will then go to that position at a rate of 200 steps/sec.</p>
<p>ERRORS: If the last position read exceeds 7000 (9999 TCF-S3), the maximum travel length, the TCF-S controller will go to the mid position or 3500 (5000 TCF-S3). This could only occur if the EEPROM chip has been replaced or is defective.</p>

Table 4-1. Start-Up (Manual Mode).

START-UP (AUTO MODE)
<p>SWITCH-SETTINGS: Mode switch is in AUTO-A or AUTO-B position Learn switch is in RUN position</p>
<p>FUNCTION: At the start, the focuser will move all the way IN focus to position 0 (HOME). The DRO will alternately display the letters TCFS and the version number. In addition, both LEDs above the IN/OUT pushbuttons will be lighted. When at home, the controller will read the last position and the last temperature before it was shutdown from the EEPROM. The focuser will then go to that position taking into account the difference between last temperature and current temperature.</p>
<p>ERRORS: If the last position read exceeds 7000 (9999 TCF-S3), the maximum travel length, the TCF controller will go to the mid-position or 3500 (5000 TCF-S3). This could only occur if the EEPROM chip has been replaced or is defective. If the new position computed using the last temperature and current temperature difference is greater than 7000 (9999 TCF-S3) or less than 0, the focuser will move to those limits and stop. In addition, the LEDs above the IN/OUT pushbuttons will flash 4 times.</p>

Table 4-2. Start-Up (Auto Mode).

MANUAL FOCUS OPERATION	
SWITCH SETTINGS:	<p>Mode switch is in MANUAL position Learn switch is in RUN position</p>
FUNCTION:	<p>The drawtube is moved in toward the direction of the telescope when the IN pushbutton is depressed and out toward the camera when the OUT pushbutton is depressed. The LED above the pushbutton will light up when the associated button is depressed. The current position is displayed on the DRO. The rate of focus travel is dependent on the duration the pushbuttons are depressed. A tapping of the pushbuttons will move the drawtube 1 or 2 steps, about 0.00008 (0.0001 TCF-S3) to 0.00016 inches. Holding the pushbuttons down will change the step rate from 6.6 steps/second to a maximum of 200 steps/second. The rate of change is not linear but geometric.</p>
ERRORS:	<p>The travel limits of 0 and 7000 (9999 TCF-S3) cannot be exceeded. The focuser will stop at those limits and only travel in the opposite direction is permitted.</p>

Table 4-3. Manual Focus Operation.

AUTO FOCUS OPERATION
<p>SWITCH SETTINGS: Mode switch is in AUTO-A or AUTO-B position Learn switch is in RUN position</p>
<p>FUNCTION: Normally, focus is obtained in the MANUAL focus mode. Once achieved, the mode slide switch is moved to either AUTO-A or AUTO-B depending on the user's optical configuration. At that instant, the current position and temperature is read and stored. Every 0.5 seconds a new temperature is read from the probe and a new position is computed dependent on any temperature change. The focus is moved to that new position by one step or 0.00008-inch (0.0001-inch TCF-S3). This loop is repeated every 0.5 seconds. All calculations are based on the initial temperature and position so that there is no accumulated error. The LED above either the IN or OUT pushbuttons, depending on which direction is selected, will flash momentarily indicating the drawtube has moved one step. While in the auto mode, pressing either the IN or OUT pushbuttons will have no effect.</p>
<p>ERRORS: The travel limits of 0 and 7000 (9999 TCF-S3) cannot be exceeded. The focuser will stop at those limits and the LED above the IN or OUT pushbutton, depending on direction traveled, will flash at a rate of 2 times per second. The user must return the mode to MANUAL and move the focuser to a more central position before proceeding with auto focus again. Of course the telescope's main focusing mechanism will have to be utilized to achieve this coarse focus change.</p>

Table 4-4. Auto Focus Operation.

LEARN OPERATION	
SWITCH SETTINGS:	<p>Mode switch is in AUTO-A or AUTO-B position Learn switch is in the LEARN position</p>
FUNCTION:	<p>It is suggested that the LEARN procedure be done with a high powered eyepiece focused on the moon or planet. This will allow accurate position to be obtained. As of August 2005, no camera control software will do an automatic LEARN procedure. This must still be done manually.</p> <p><i>Step 1.</i></p> <p>At the start of the LEARN operation the word SET is displayed on the DRO. Using the IN/OUT pushbuttons, focus as in the MANUAL mode. Once exact focus is obtained with either eyepiece or CCD camera, press the PROGRAM pushbutton to store initial position and temperature. After a slight delay, the temperature difference ΔT between initial temperature and current temperature is displayed on the DRO.</p> <p><i>Step 2.</i></p> <p>The TCF can now be used as in the MANUAL mode for keeping the object in focus. However, because of software overhead during this operation there may be a slight delay from pressing either the IN or OUT pushbuttons and movement of the focuser drawtube. During movement the current position is displayed on the DRO for a brief time but then returns to display the temperature difference between initial and current temperature. It is recommended that a temperature difference of at least 5°C be observed before proceeding with completing the LEARN operation. The DRO will only display a temperature difference up to 9°C but can use larger values internally. However, there will only be a slight increase in precision by using values larger than 9°C. Typically for a 5°C temperature change, a Schmidt-Cassegrain telescope will show approximately a 450 step change in focus.</p> <p><i>Step 3.</i></p> <p>At any time up to this point the LEARN operation can be aborted and the old values kept by moving the LEARN slide switch back to the RUN position. After an adequate temperature change is observed, press the PROGRAM pushbutton and keep it depressed until the word DONE is displayed on the DRO. At this time, the new temperature coefficient for the selected AUTO-A or AUTO-B is stored in the EEPROM. The LEARN slide switch must now be moved to the RUN mode before the unit will operate.</p>
ERRORS:	<p>A temperature difference greater than 16°C during the LEARN operation may cause over-range errors to occur with unpredictable results. Keep the temperature difference to less than 9°C.</p>

Table 4-5. Learn Operation.

SHUTDOWN
<p>SWITCH SETTINGS: Mode switch in any position Learn switch in RUN position</p>
<p>FUNCTION: When the power switch is placed in the OFF position, there is a momentary delay as the internal PIC microcontroller writes the current position and temperature to the EEPROM. Once done, the unit will shut down.</p>
<p>ERRORS: The current position and temperature will not be written to the EEPROM if the power is interrupted or shut down by means other than the ON/OFF power switch. However, the old values will remain intact.</p>

Table 4-6. Shutdown Procedure.

SECTION 5.0

PC SOFTWARE CONTROL

There are now two models of the TCF focuser – the older and out of production TCF temperature compensating focuser and the newer and improved TCF-S serial version which uses a RS-232 protocol to communicate with an external computer.

5.1 TTL LEVEL CONTROL FOR TCF AND TCF-S (**THIS FEATURE IS OBSOLETE IN NEW UNITS**)

With both the older TCF and the newer TCF-S, the IN and OUT pushbuttons can be operated remotely through the 6-pin modular interface connector.

This mode of operation uses pins 2, 4 and 5 of the 6-pin modular jack on the TCF or TCF-S controller. (See Appendix A to locate the pins.) These pins emulate the IN/OUT pushbuttons so that logic 1 on pin 2 would, in a sense, depress the OUT pushbutton for as long as the port is held high and a logic 1 on pin 5 would depress the IN pushbutton. Pin 4 is common.

All input signals require TTL voltage levels (0 to +5 volts) and have an input impedance of approximately 1K Ω . Debounce circuitry is not needed since it is built into the software that controls these ports. The ports are normally held low through a 100K resistor so that an open port condition will not result in erratic behavior. The parallel port from any PC computer should have no trouble providing these levels. In addition, pins 2 and 5 are protected against overvoltage and reverse voltage conditions within common limits.

5.2 ADVANCED TTL CONTROL FOR THE TCF

The second mode for the older TCF is designed for advanced programmers only. The mode has been jumper disabled on the TCF-S to allow for the serial interface. The user should contact Optec if this mode of control is desired with a model TCF-S knowing that the serial interface will be disabled. This mode of computer controlled focusing uses pin 3 of the 6-pin modular connector to send position change information to the TCF focuser. Pins 2 and 5 are used to determine which direction to move. Like pins 2 and 5, pin 3 requires TTL level signals and is protected against overvoltage and reverse voltage conditions within common limits.

The method of control is as follows:

1. Initial conditions: pins 2, 3 and 5 are at logic 0.
2. Pin 3 (PC) is brought high.
3. Pin 2 (or 5) OUT (or IN) direction pin is brought high.

4. Delay at least 15 ms but not more than 3 seconds. If a delay longer than 3 seconds is incurred before going to step 5, the device will time out and the OUT LED will flash 10 times before returning to the main routine.
5. Toggle pin 3 (high - low - high) with the duration of the pulse divided by 5μ seconds equal to the number of steps to be moved.
6. The TCF focuser will move to the new position at 100 steps/second.
7. Bring pins 2, 3 and 5 to a logic 0 before the TCF focuser completes its movement. Note that each focus step change will require 10 msec to complete.
8. Do not initiate another focus command until the TCF focuser has completed the first movement. Note that the total time to wait would be the total number of steps to move times 10 ms.

Pulses up to 0.328 seconds are acceptable but these would exceed the travel limits of the TCF focuser. It is suggested that pulse widths not exceed 0.01 seconds, which would move the focuser through 200 steps. Since there is no position feedback to the PC computer, it is up to the programmer to allow initial position information to be keyed into the program.

5.3 TCF-S/TCF-S3 - RS-232 SERIAL COMMUNICATIONS

Optec's Model TCF-S and TCF-S3 provides an RS-232 serial communications option for the temperature compensating focuser. The hand controller of the TCF-S/TCF-S3 includes built-in circuitry with a RS-232 driver allowing the user to communicate with the focuser from any external PC. Using simple ASCII commands this focuser can be moved in or out, set into either of the automatic modes, or queried for position and temperature. There is even an advanced "Sleep" mode allowing the user to place the focuser into low power operation remotely. The focuser can then be restarted remotely at a later time.

Optec supplies a windows based control program for complete operation of the TCF-S/TCF-S3. This program is described in Appendix E and available for download at www.optecinc.com.

5.3.1 CONNECTING THE TCF-S/TCF-S3 TO THE PC

For the physical wiring connection between the PC and the TCF-S, Optec recommends our PC serial port converter (stk. #17695) and an RJ-12 reverse cable. Optec offers a number these cables in lengths from 6-ft to 50-ft. Custom cables can also be ordered. The reverse cable is wired pin 1 to pin 1, pin 2 to pin 2, etc. A six-wire flat cable with RJ-12 connectors on each end works well up to at least 120 ft. (Refer to Appendix A for wiring details.)

The RS-232 implementation used with the TCF-S is a simple 3-line interface using RX, TX, and GND. (Refer to Appendix A for wiring details.)

5.3.2 COMMUNICATIONS PROTOCOL

The remote PC communication program should be set for 19.2k-baud rate with 8 data bits, 1 stop bit, and no parity (8N1). The TCF-S/TCF-S3 is preset for these values and will not respond to other settings. **Be sure to set the baud rate to 19.2K BAUD before attempting communication with the TCF-S.** Tables 5-1 through 5-11 below describe in detail the commands used to control and communicate with the TCF-S/TCF-S3. To establish communications a Focuser Manual Mode (FM MODE) command must be sent along the serial line to the focuser. This command should consist of the ASCII serial string “FM MODE” (without the quotes). If a partial command string is received, the TCF-S/TCF-S3 controller will timeout after only a few milliseconds and may not parse the entire command string properly. The controller program may timeout between characters when sent one at a time. PROCOMM can be used successfully in the chat or host mode where the string command is not sent until a CR/LF is typed. Once the FM MODE command has been received and accepted by the TCF-S/TCF-S3, a return character of “!” (followed by a CR/LF) will be sent back to the PC communications program. None of the other commands will work before the FM MODE command has properly initialized the serial connection.

Once the serial connection is active, there are commands available to center the focuser, move it in or out any number of steps, read the current focuser position and temperature, or to set the focuser into either the A or B automatic modes. Note that serial communications will only occur if the hand control slide switch is in the Manual position. The Learn slide switch must be in the Run position. Each command is described separately in the tables below.

The FAMODE and FBMODE commands simulate the Auto-A and Auto-B modes using the same temperature coefficient values stored in the TCF hand controller memory. While in either of these automatic modes, all serial input is ignored except for the FM MODE, which returns the communications, program to manual operation. The LEARN operation for deriving the A and B mode temperature coefficients is not implemented into the serial routines and must be performed manually as describe in Section 4.0 (Table 4.5) above.

For the truly remote observatory a special low-power “Sleep” mode is available. The FSLEEP command will drop the TCF-S/TCF-S3 into a hibernation mode that simply checks for a wake-up command (FWAKUP) along the serial line. The remote user can restart the focuser as long as the TCF hand controller has not lost power. See Tables 5-10 and 5-11 below.

When the communications session is complete, the Focuser Free Command (FFMODE) will terminate the serial connection. See Table 5-11 below.

5.3.3 TCF-S/TCF-S3 COMMANDS

LF = line feed, CR = carriage return, n = number from 0 to 9, x = any character

Command	Return
FMMODE (Focuser Manual Mode)	"!" LF CR
<p><i>Function:</i></p> <p>This command initializes the serial connection between the PC and the TCF-S/TCF-S3. FMMODE causes the TCF-S/TCF-S3 program to enter into the main serial loop which checks for additional inputs along the RJ-12 connector. A successful return from this command ("!" LF CR) is required before the TCF-S/TCF-S3 will accept any other user commands. FMMODE also allows the user to exit the serial AUTO-A and AUTO-B mode loops. (See warning)</p>	
<p><i>Warning:</i></p> <p>The FMMODE command may need to be executed more than once to successfully exit the serial AUTO loops. The user will see the return character for FMMODE after the serial AUTO loop has been successfully exited.</p>	

Table 5-1. Focuser Manual Mode Command.

Command	Return
FAMODE (Focuser Auto-A Mode)	"P=" nnnn LF CR "T=" ±nn.n LF CR
<p><i>Function:</i></p> <p>This command puts the TCF-S/TCF-S3 in the serial mode AUTO-A. This mode is the same as the non-serial mode AUTO-A. It even uses the same "learned" slope value. The only difference between the two is that the serial version transmits the current position and temperature to the PC. There is a 10ms pause between the position and temperature transmissions. To exit this mode the user must execute the FMMODE command. FQUITn stops the temperature and position telemetry.</p>	

Table 5-2. Focuser A Mode Command.

Command	Return
FBMODE (Focuser Auto-B Mode)	“P=” nnnn LF CR “T=” ±nn.n LF CR
<p><i>Function:</i></p> <p>This command puts the TCF-S/TCF-S3 in the serial mode AUTO-B. This mode is the same as the non-serial mode AUTO-B. It even uses the same “learned” slope value. The only difference between the two is that the serial version transmits the current position and temperature to the PC. There is a 10ms pause between the position and temperature transmissions. To exit this mode the user must execute the FMMODE command. FQUIT stops the temperature and position telemetry</p>	

Table 5-3. Focuser B Mode Command.

Command	Return
FI$nnnn$ (Focuser In “ $nnnn$ ”)	“*” LF CR
<p><i>Function:</i></p> <p>This command allows the user to move the focuser in by a specific number of steps. The “IN” direction corresponds to lower absolute position numbers. The number “$nnnn$” should be padded with zeros to four characters. That is, if the focuser needs to be moved in by 5 steps, the proper command string would be FI0005. The FI$nnnn$ command will accept user inputs in the range of 0 to 7000 (9999 for TCF-S3). However, the TCF-S/TCF-S3 cannot physically move past the zero position.</p>	
<p><i>Warning:</i></p> <p>Entering a value such as 159, as opposed to 0159, will cause the TCF-S/TCF-S3 to move to an undesired position. Remember to right adjust all position values less than 1000.</p>	

Table 5-4. Focuser In Command.

Command	Return
FOnnnn (Focuser Out “nnnn”)	“*” LF CR
<p><i>Function:</i></p> <p>This command allows the user to move the focuser out by a specific number of steps. The “OUT” direction corresponds to higher absolute position numbers. The number “nnnn” should be padded with zeros to four characters. That is, if the focuser needs to be moved out by 750 steps, the proper command string would be FO0750. The FOnnnn command will accept user inputs in the range of 0 to 7000 (9999 for TCF-S3) . However, the TCF-S cannot physically move past position 7000 (9999 TCF-S3).</p>	
<p><i>Warning:</i></p> <p>Entering a value such as 159, as opposed to 0159, will cause the TCF-S/TCF-S3 to move to an undesired position. Remember to right adjust all position values less than 1000.</p>	

Figure 5-5. Focuser Out Command.

Command	Return
FPOSRO (Focuser Position Read Out)	“P=nnnn” LF CR
<p><i>Function:</i></p> <p>This command allows the programmer to request the focuser’s current position. The TCF-S/TCF-S3 will respond with the right justified position information. Since the serial feature of the TCF-S allows remote control of the controller, the user would need to have a position reading to chart the progress of the TCF-S/TCF-S3 at that remote location. This command works nicely with the FI$nnnn$ command, the FO$nnnn$ command, and the FCENTR command. The programmer can request the current position information before moving the focuser to ensure that it stays within the operating range of 0000 to 7000 (9999 for TCF-S3).</p>	

Figure 5-6. Position Read-Out Command.

Command	Return
FTMPRO (Focuser Temperature Read Out)	"T=±nn.n" LF CR
<p><i>Function:</i></p> <p>This command allows the programmer to request the current probe temperature. The TCF-S/TCF-S3 program does not display the temperature on the hand controller DRO. (The Learn operation displays only the temperature differential.) For advanced focus algorithms a programmer may need current temperature information. The FTMPRO command provides access to this information. Note: when in either of the automatic modes, FAMODE or FBMODE, the FTMPRO command is ignored. However, each of these modes returns position and temperature information continually. The temperature is measured and displayed in positive or negative degrees Celsius and has an accuracy of ± 0.1 degree.</p>	

Figure 5-7. Temperature Read-Out Command.

Command	Return
FCENTR (Focuser Center)	"CENTER" LF CR
<p><i>Function:</i></p> <p>This command prompts the TCF-S/TCF-S3 to move to the center position of its full range, which is 3500 (5000 for TCF-S3). FCENTR can be used to center the focuser at the beginning of any observing session. The programmer might choose to use the FCENTR command and then prompt the telescope user to focus with the coarse telescope focuser. This procedure optimizes the distance traveled in either direction.</p> <p>As well as sending the return string("CENTER") to the PC, the TCF-S also acknowledges arriving in the center position by turning on both the IN and OUT LED's on the controller for a moment and then turning them both out.</p>	

Figure 5-8. Focuser Center Command.

Command	Return
FSLEEP (Focuser Sleep)	"ZZZ" LF CR
<i>Function:</i>	
<p>This command performs the shutdown procedure of the TCF-S/TCF-S3, however it does not completely power down. The SLEEP mode allows the PIC micro-controller to remain active and susceptible to the FWAKUP command. The final position and the start temperature are recorded into memory and the TCF-S shuts off the power to the stepper motor and to the display, which is the majority of power consumption within the TCF-S/TCF-S3. The power LED will blink slowly to inform the user of the restful state that the TCF-S is in.</p> <p>Powering down the TCF-S/TCF-S3 is also possible at this point. This command is useful when the user has multiple devices on a power-strip and it is not convenient to shut them off one at a time.</p>	

Figure 5-9. Focuser Sleep Command.

Command	Return
FWAKUP (Focuser Wake Up)	"WAKE" LF CR
<i>Function:</i>	
<p>This command's only use is to wake up the TCF-S/TCF-S3 from its SLEEP mode. Once the user has issued this command, the TCF-S/TCF-S3 restores power to the display and the stepper motor. The final value of the position is also restored to the display from memory. The only time this command can be used is if the TCF-S/TCF-S3 is in SLEEP mode.</p>	

Figure 5-10. Focuser Wake-up Command.

Command	Return
FREADA or FREADB (Focuser Read Slope Command)	“A=0nnn” or “B=0nnn” LF CR
<i>Function:</i>	
<p>This command reads the learned slope values stored in the EEPROM for the AUTO-A or AUTO-B switch settings. Values from 0000 to 0999 can be read. The default value stored in both locations is 086, which is the slope constant for the Meade 10-inch telescope located in the Optec Observatory.</p>	

Figure 5-11. Focuser Read Commands.

Command	Return
FLAnnn or FLBnnn (Focuser Load Slope Command)	“DONE” LF CR
<i>Function:</i>	
<p>This command writes the slope values to the EEPROM for the AUTO-A or AUTO-B switch settings. Values from 000 to 999 can be loaded. The integer slope value represents the number of steps (0.00008 inches) that the focuser moves for every Centigrade degree change in temperature.</p>	

Figure 5-12. Focuser Load Commands.

Command	Return
FQUITn (Focuser Quiet Command – <i>firmware ver. 2.21 and above</i>)	“DONE” LF CR
<i>Function:</i>	
<p>This command can disable the position and temperature data from being returned to the PC during FAMODE or FBMODE. The default is $n = 0$ which returns the telemetry data every second. A value of $n = 1$ will disable all telemetry data.</p>	

Figure 5-13. Focuser Quiet Command.

Command	Return
FDAnnn or FDBnnn (Focuser Delay Command – <i>firmware ver. 2.21 and above</i>)	“DONE” LF CR
<i>Function:</i>	
<p>The default delay between step movements during temperature compensation (A or B mode) is 1.00 seconds. This delay between steps can be increased using this new command. Values of 001 to 999 correspond to 0.01 seconds to 9.99 seconds of additional delay. The default value of 000 is restored after the power is turned off. Note that this command only works with the software FAMODE and FBMODE and not the manual selected Auto-A and Auto-B modes. This command can only be issued while the TCF-S/TCF-S3 is in FM MODE (as opposed to FAMODE or FBMODE). (example: FDA400 will increase the default delay for FAMODE from 1.00 second to 5.00 seconds.)</p>	

Figure 5-14. Focuser Delay Command.

Command	Return
FHOME (Focuser Home Command – <i>firmware ver. 2.21 and above</i>)	“DONE” LF CR
<i>Function:</i>	
<p>Similar to turning off the unit when in RUN mode (no PC) with the switch in Auto-A or B and then turning the TCF-S back on at a different time and temperature. Intended to be used with FSLEEP, which saves the current temperature and position information, and the FWAKUP command which does not automatically compensate for a change in temperature that may have occurred while in “Sleep” mode. Command sequence is FxMODE (x = A or B), FM MODE, FSLEEP, ... FWAKUP, FHOME. FHOME will use the temperature coefficient stored for A or B depending on which FxMODE command was last issued and move the focuser to the new calculated position.</p>	

Figure 5-15. Focuser Home Command.

Command	Return
FFMODE (Focuser Free Mode)	“END” LF CR
<i>Function:</i>	
<p>The user issues this command when the remote controlling session of the TCF-S/TCF-S3 is over. Upon executing this command the user relinquishes control back to the TCF-S/TCF-S3 controller and frees it from serial control. This command will only work if the serially controlled TCF-S/TCF-S3 is in FMMODE.</p>	

Figure 5-16. Focuser Free Mode Command.

Command	Return
FtxxxA or FTxxxB (Slope sign Command – <i>firmware ver. 2.32 and above</i>)	“A=n” or “B=n” LF CR
<i>Function:</i>	
<p>The sign of the slope is reported back. Most telescopes have a positive (n=0) sign but some of the Takahashi models have a negative (n=1) sign. Use the FZXxxn command to input new sign values.</p>	

Figure 5-17. FocuserRead Slope Sign Command.

Command	Return
FZAxxn or FZBxxn (Load slope sign Command – <i>firmware ver. 2.32 and above</i>)	“DONE” LF CR
<i>Function:</i>	
<p>This command allows the sign of the slope to be changed from positive to negative. Previous versions always assume a positive sign. Some of the Takahashi telescopes have slope values with a negative sign. A positive slope is designated with n = 0 and a negative slope with n = 1.</p>	

Figure 5-18. Focuser Load Slope Sign Command.

SECTION 6.0

TROUBLE SHOOTING

A new feature for TCF firmware versions 2.10 and later is the reporting of error codes for certain fault conditions. These error messages are displayed on the DRO and are also reported on the serial port. Currently, the following errors are reported:

ER=1 Temperature probe not connected or not working.
This is the most common fault and can usually be traced to a missing temperature probe or faulty wiring. Check the temperature probe connection first. [A temperature probe and socket upgrade (stk. #17558) which replaces the 2.5mm phono type connector from the original design TCF-S/TCF-S3 with the more robust current style PS2 type connector is available from Optec for a nominal charge.] Also check the Control cable connection at the TCF hand control.

If the PC serial control cable is inadvertently plugged into the RG-45 connector (J2 in Appendix B for board layout) for the control cable going to the TCF-S/TCF-S3, pins 1 and 8 may be pushed back and not make contact. Pin 1 is the ground pin for the temperature probe which will disable the probe if is not connected. Examine the pins of the RJ-45 connector using a good light and magnifier and see if all the pins are lined up evenly. If not, use a knitting needle to bend pins 1 and 8 back in line.

ER=2 New calculated position when unit turned on in AUTO-A or AUTO-B exceeds limits.
Try re-centering the focuser and adjusting the telescope's coarse focus.

ER=3 EEPROM failed read/write test on boot up.
Contact Optec is this error condition occurs repeatedly.

Listed below are common concerns and fixes mentioned by TCF users.

1. The focuser will not move past position 7000 (9999 for TCF-S3) or 0. If the focuser is moved to these limits, it will stop and can only be moved in the opposite direction.
2. While in the AUTO mode, very slight vibrational pulses may sometimes be felt while touching the TCF-S/TCF-S3 focuser. This is caused by the stepper motor moving by one step increments under command of the controller. While in either AUTO mode these pulses may come at a rate of 1 per second. Under careful observations with a Meade LX200 10 inch telescope, no image jitter was ever observed with a high-powered eyepiece. These vibration pulses may only be of concern during very high magnification planetary imaging. During that application, it might be recommended to place the unit in the MANUAL mode just before initiating the exposure and then going back to AUTO right after. The FDA_{nnn} or FDB_{nnn} commands could be used to increase the period between temperature compensation steps.

3. If, during a LEARN operation, the ambient temperature changes by more than 16° and the procedure is not completed, an internal over-range error may occur with unpredictable results (divide by 0). Monitor the temperature difference, and complete the LEARN operation before a 9°C difference is reached.
4. In a vertical position, a heavy instrument package may cause slipping between the drive shaft and the drawtube. This is a common problem with Crayford style mounts and cannot easily be remedied. Loads of 8 to 10 pounds will probably result in a small amount of slippage when in the vertical position. Loads of 6 pounds and less will not slip. Call Optec if slippage is a problem for your application.
5. If the unit acts erratic when in the AUTO mode it could be the result of strong interference upon the temperature probe. The temperature probe uses a digital signal sensor, which should be immune to most noise sources. However, running long lengths of controller cable over noise sources such as computers, switching power supplies or fluorescent light may cause temperature read errors.
6. If pulses are slow in coming while in auto mode or if there is an unexpected delay when the unit is powered down, the fault is probably with the temperature probe. Check to make sure the temperature probe is properly connected.
7. After considerable use, the friction surface of the drawtube may become worn. The first production runs of the drawtube specified standard anodizing. Optec now specifies a hard-coat anodizing which slows wear appreciably. If slipping becomes a problem, Optec can exchange the drawtube with a rebuilt one having a new hard-coat anodized surface. Contact Optec for details and cost.
8. Sometimes the three screws holding the stepper motor in position become loose. Remove the cover protecting the gearing and tighten the motor screws with an allen key wrench. Do not over tighten which might strip the screws.
9. Plugging the PC control cable into the RJ-45 connector for the control cable going to the TCF-S, may bend pins 1 and 8 back causing them not to make contact with the cable connector. If pin 1 is not connected, an ER=1 error will be seen. If pin 8 is not connected, the stepper motor will sound as if it is moving but the drawtube will not move. Examine the pins with a strong light and a magnifier to see if they are all lined up evenly. If not, use a knitting needle to bend the pins back in line.

SECTION 7.0

SPECIFICATIONS for TCF-S

FOCUSER

Type	Crayford Style
Length of focus travel	0.60" (1.0" for TCF-S3)
Minimum step movement	0.000085" (0.0001 for TCF-S3)
Maximum step rate	200 steps/sec
Total Backlash	typically 0.0015" (18 steps)
Maximum instrument load	10 lbs. (20 lbs. for TCF-S3)
Total gear reduction ratio	192:1 (240:1 for TCF-S3)
Focuser drive gear	96 teeth, (120 for TCF-S3) 2024 alloy, quality 10
Motor spur gear	25 teeth, 303 stainless, quality 10
Controller connector	9-pin sub-D, pins
Temperature connector	6-pin mini DIN
Weight	2 lbs. 8 oz. (4lbs. 8 oz for TCF-S3)
Length	3.28" with drawtube at 0 position (4.3" for TCF-S3)
Operating temperature	-40°C to 50°C

CONTROLLER

Type	PIC microcontroller, 16F7x series
I/O ports	22
Clock frequency	8 MHz
CPU Memory	8 EPROM (4 EPROM for TCF) 192 bytes RAM
EEPROM	256 bytes
Focuser connector	8-pin modular jack, RJ45 type
PC connector	6-pin modular jack, RJ12 type
Power connector	2.5 mm power jack
Power	12 VDC , 230 to 350 ma
Size	5.6 x 3.2 x 1.5 inches (L x W x H)
Weight	6 oz.

TEMPERATURE SENSOR

Type	Analog Devices TMP03
Temperature range	-40°C to 100°C
Linearity	0.5°C
Output	modulated serial digital TTL signal
Cable length	18" standard

POWER SUPPLY

Input	100 - 240 VAC, 50/60 Hz, 0.4 A
Output	12 VDC, 1A regulated
Input connector	IEC 320/7
Listed by	UL, CSA, CE
Output Connector	2.5 mm power plug
Center Pin	positive

Appendix A

WIRING DIAGRAM

TCF CONTROL CABLE 8 WIRE, 24 AWG		
PIN	COLOR	FUNCTION
1	DRG-WHI	GND
2	DRG	+12 VDC
3	GREEN-WHI	TEMP IN
4	BLUE	+5VDC
5	BLUE-WHI	STEP/T1, BLK
6	GREEN	STEP/T3, BROWN
7	BROWN-WHI	STEP/T2, DRG
8	BROWN	STEP/T4, YEL
9		NC

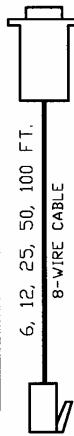

8-PIN MODULAR
8-WIRE CABLE
9-PIN SUB-D
FEMALE CONN. PN3502

PC/TCF CONTROL CABLE			
MOD. PIN	COLOR	FUNCTION	PC SERIAL DB-9 PIN COLOR
1	WHITE	RS-232, RX	3 (TX) WHITE
2	BLACK	BUTTON_OUT	
3	RED	PULSE	
4	GREEN	GND	5 (GND) GREEN
5	YELLOW	BUTTON_IN	2 (RX) BLUE
6	BLUE	RS-232, TX	

FRONT VIEW
654321

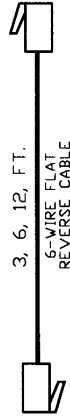

6-PIN MODULAR
6-WIRE FLAT
REVERSE CABLE
6-PIN MODULAR

TEMPERATURE PROBE CABLE

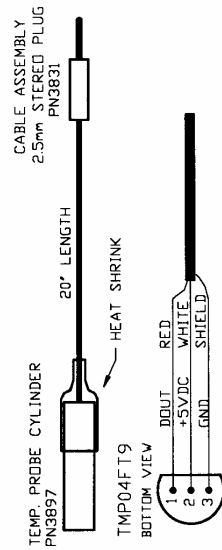

TEMP. PROBE CYLINDER
PN3897
CABLE ASSEMBLY
2.5mm STEREO PLUG
PN3831

20' LENGTH
HEAT SHRINK
TEMP04FT9
BOTTOM VIEW
1 DOUT
2 +5VDC
3 GND
RED
WHITE
SHIELD

NOTES:

1. USE 26AWG STRANDED WIRE
2. USE HEAT SHRINK ON ALL SOLDER CONNECTIONS

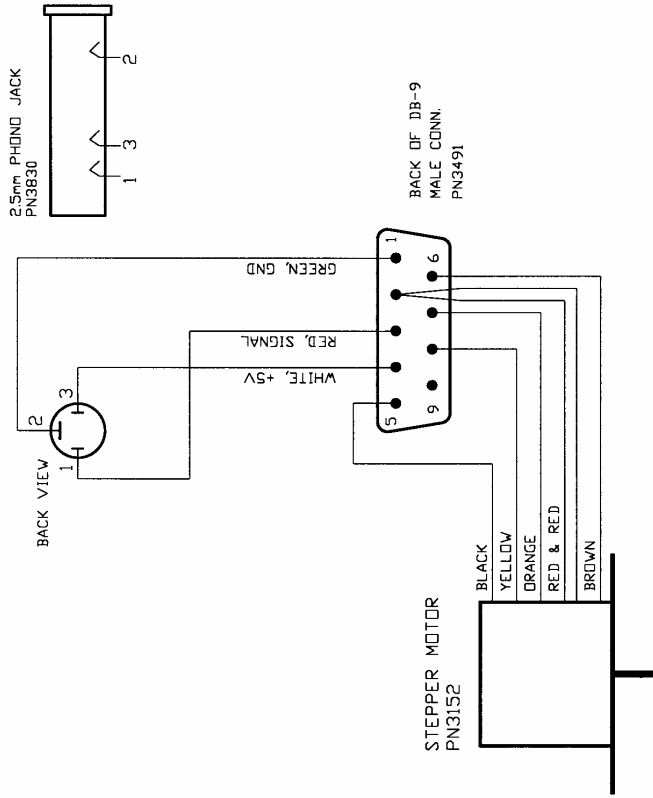

CONTRACT
TCF

REVISION
2/11/00 12/7/2001
5/16/2000
8/16/2000
11/14/2000

OPTEC, Inc.

TCF WIRING DIAGRAM

SCALE:

ND: 17-06623

TCF CONTROL CABLE 8 WIRE, 24 AWG		
PIN	COLOR	FUNCTION
1	ORG-WHI	GND
2	DRG	+12 VDC
3	GREEN-WHI	TEMP_IN
4	BLUE	+5VDC
5	BLUE-WHI	STEP/T1, BLK
6	GREEN	STEP/T3, BROWN
7	BROWN-WHI	STEP/T2, DRG
8	BROWN	STEP/T4, YEL
9		NC

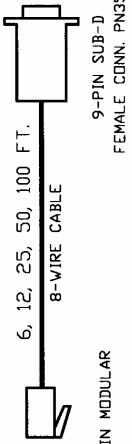

PC/TCF CONTROL CABLE				
MOD. PIN	COLOR	FUNCTION	PC PAR. PORT DB-25	PC SERIAL DB-9 PIN COLOR
1	WHITE	RS-232, RX		3 (TX) WHITE
2	BLACK	BUTTON_OUT		
3	RED	PULSE		
4	GREEN	GND	USER DEFINED	5 (GND) GREEN
5	YELLOW	BUTTON_IN		2 (RX) BLUE
6	BLUE	RS-232, TX		

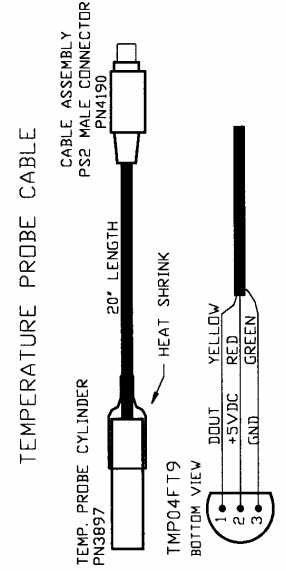
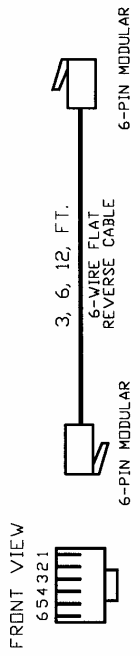

NOTES:
1. USE 26AWG STRANDED WIRE
USE HEAT SHRINK ON ALL SOLDER CONNECTIONS

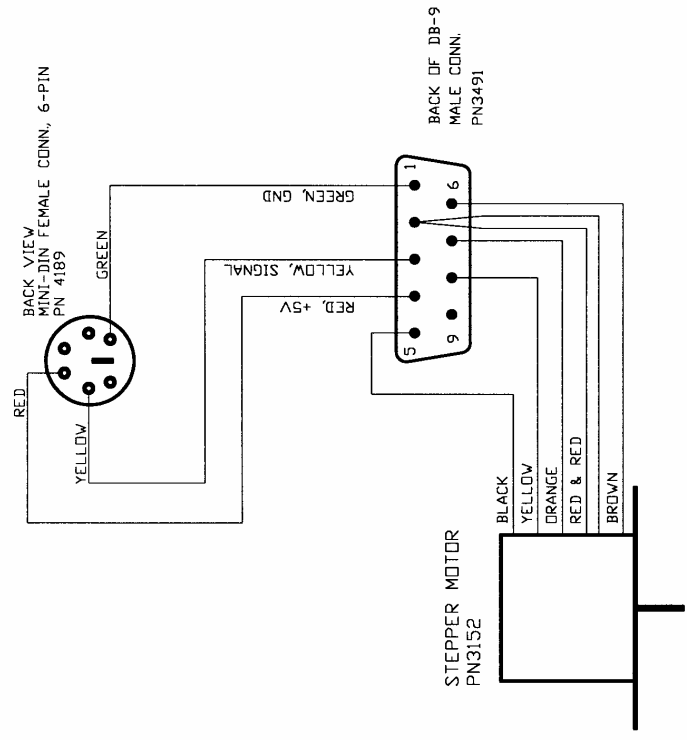

CONTRACT TCF	<i>OPTEC, Inc.</i> TCF WIRING DIAGRAM WITH MINI-DIN 6-PIN	SCALE: NO: 17-06625
REVISION 7/10/2002		

Appendix B

CONTROLLER BOARD LAYOUT

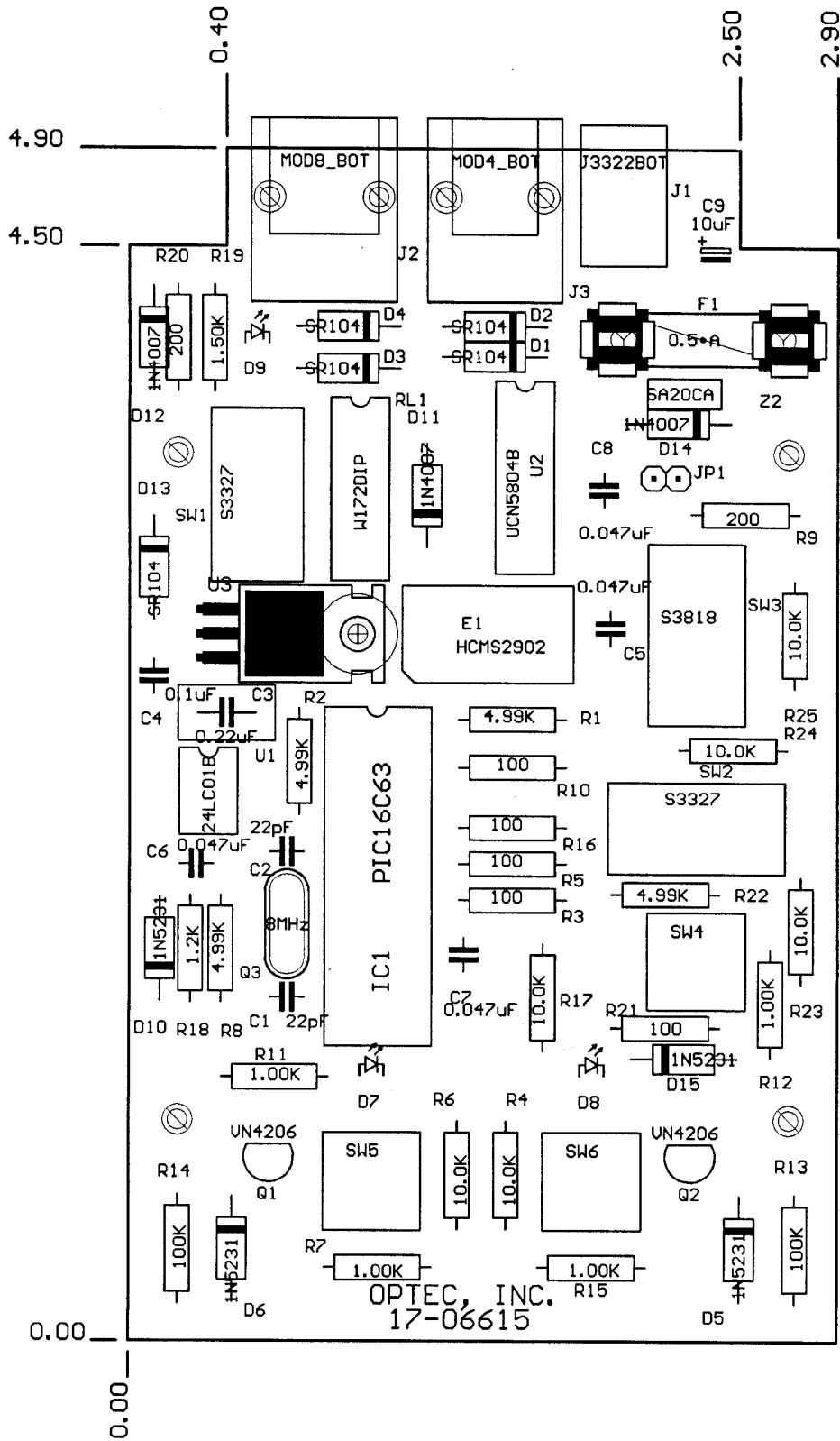

Original TCF Hand Controller Circuit Board Layout.

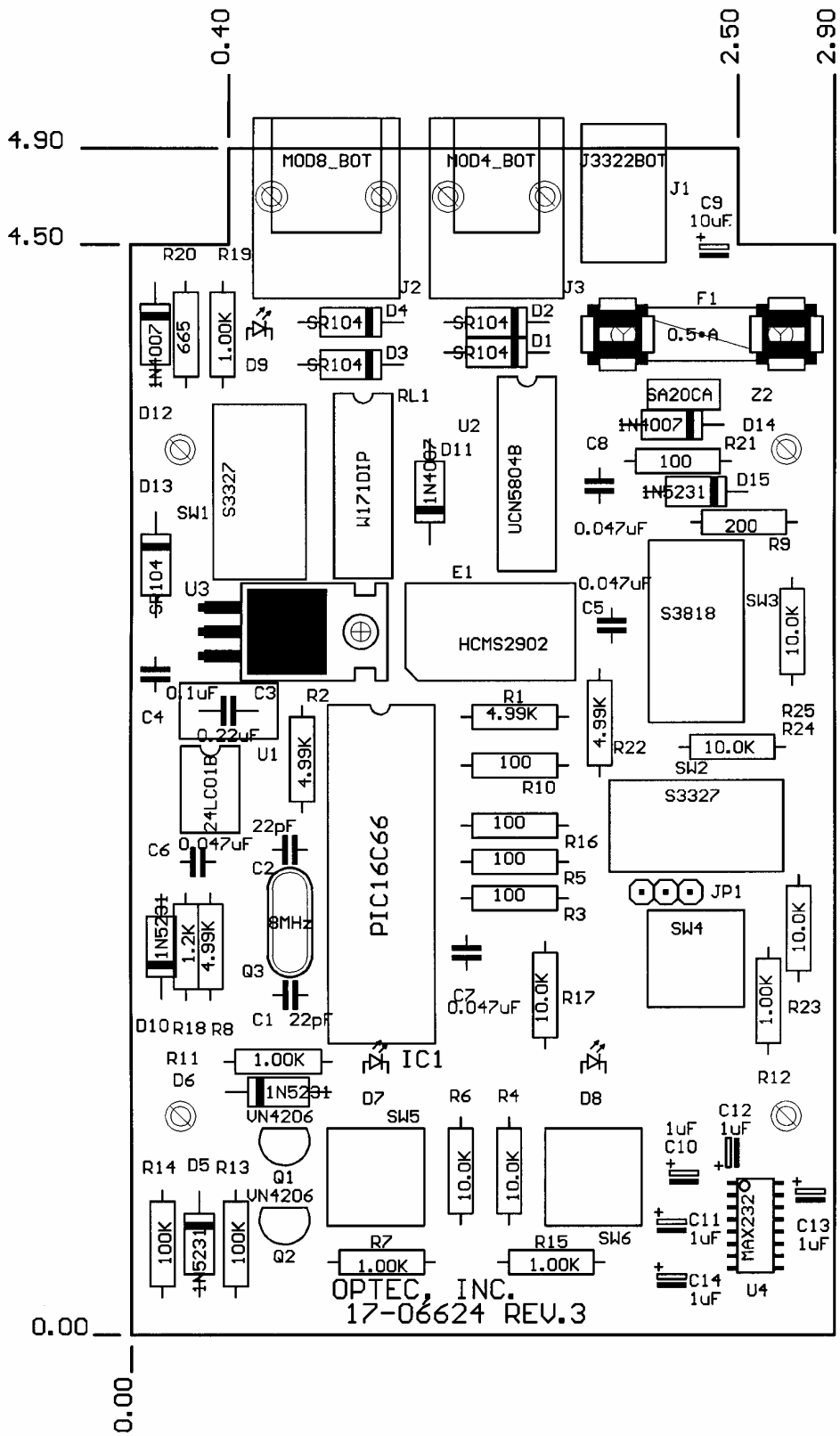

TCF-S Hand Controller Circuit Board Layout.

Appendix C

CONTROLLER BOARD CIRCUIT

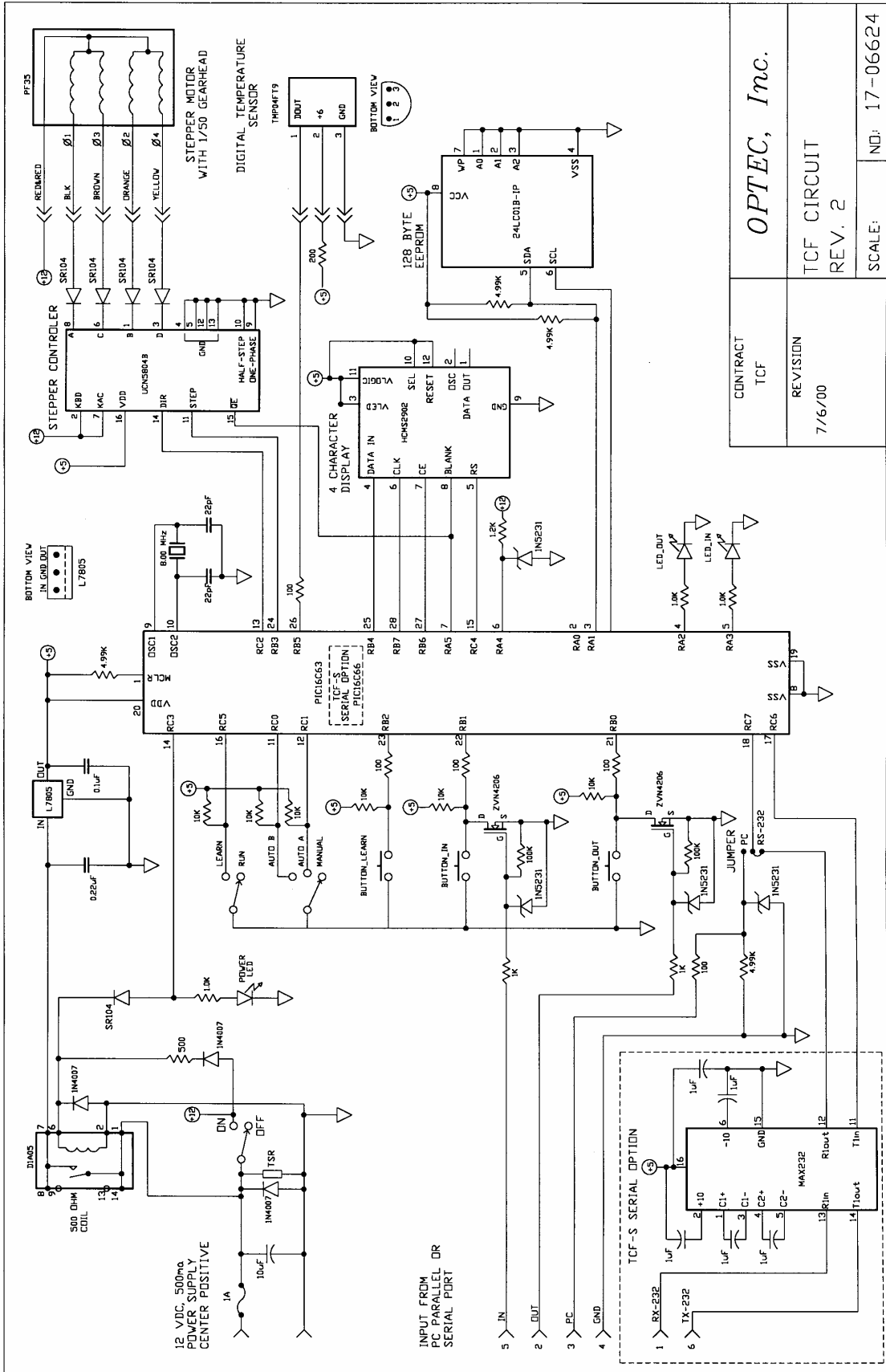

OPTEC, Inc.

TCF CIRCUIT
REV. 2

Appendix D

TCF-S CONTROL USING CCDSOFT VERSION 5

Software Bisque has developed an automatic focusing routine called @Focus as part of the CCDSoft* Version 5 software package. Using the TCF-S focuser with this package is easy but does require a bit of understanding. This appendix attempts to provide that understanding. It is strongly recommended the user also read the *CCDSOFT Manual* available in PDF format from Software Bisque's website at www.bisque.com. Specifically, read and understand the section covering the CCD Camera Panel. The information contained in this appendix pertains to CCDSoft Version 5.00.112. Later versions of the software may have changes to the current TCF-S implementation.



To setup CCDSoft for use with the TCF-S, open the Camera Control window by clicking Setup under the Camera menu. For "Focuser", select Optec TCF-S. Set the correct communications port number and accept the default "Step size" and "Backlash" parameters.

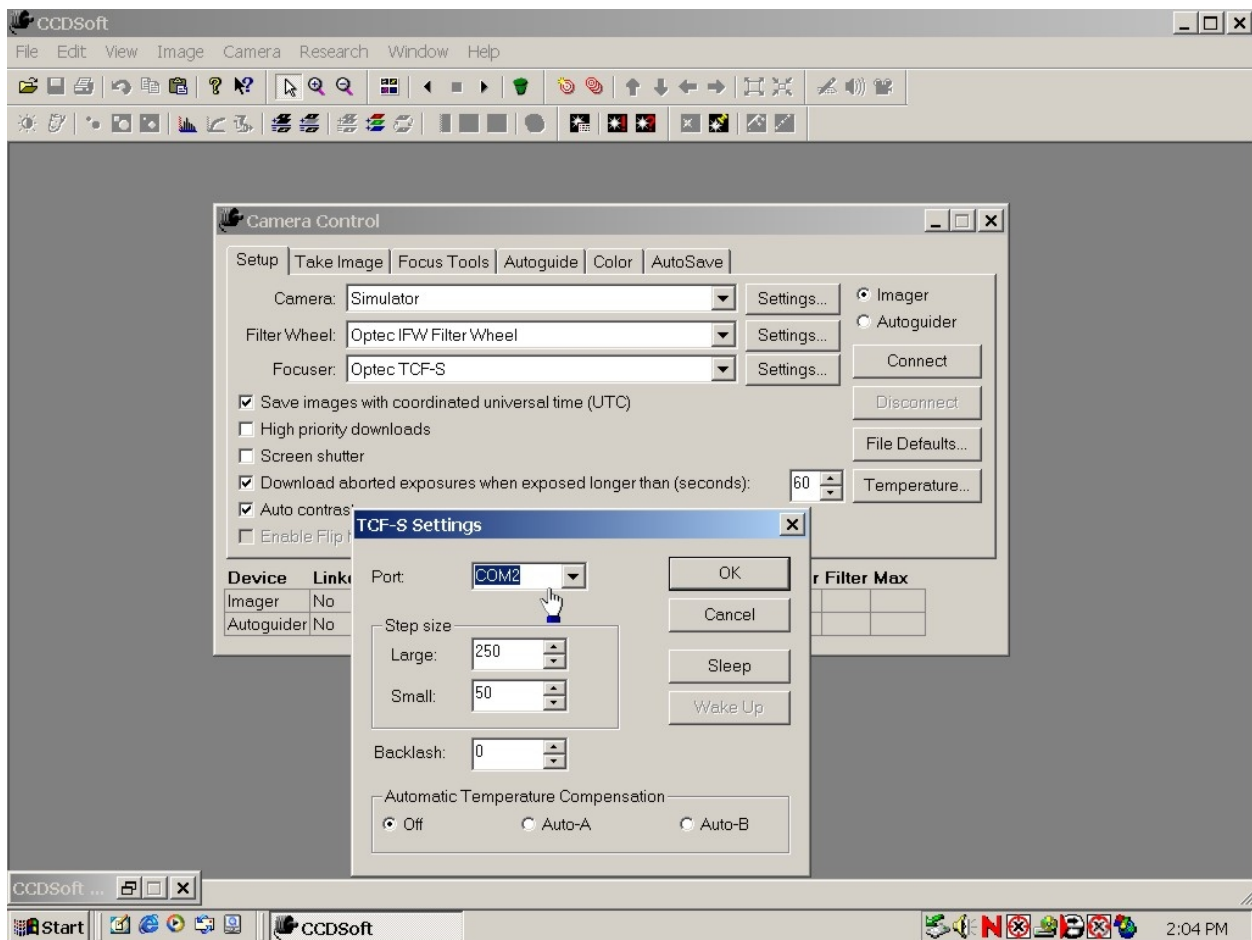

Initially, leave the Automatic Temperature Compensation “Off”. The “Auto-A” and “Auto-B” option selections will place the TCF-S into either A or B mode through software. Do not adjust the slide switch on the hand controller.

When you click the “Connect” button the software will send the appropriate command (FM MODE) to the TCF-S through the serial port. With CCDSoft version 5.00.089 and later, the “Disconnect” button will properly release the focuser and communications port. Remember, while under CCDSoft or any other software control the IN and OUT buttons on the hand control will be inoperative. However, CCDSoft allows the PC user to move focus IN and OUT under the Focus Tools tab as shown below. Control can be regained by the TCF-S hand control from CCDSoft by simply clicking the “Disconnect” button under the Setup tab of the Camera Control window. Refer to the CCDSoft documentation for information on @Focus settings.

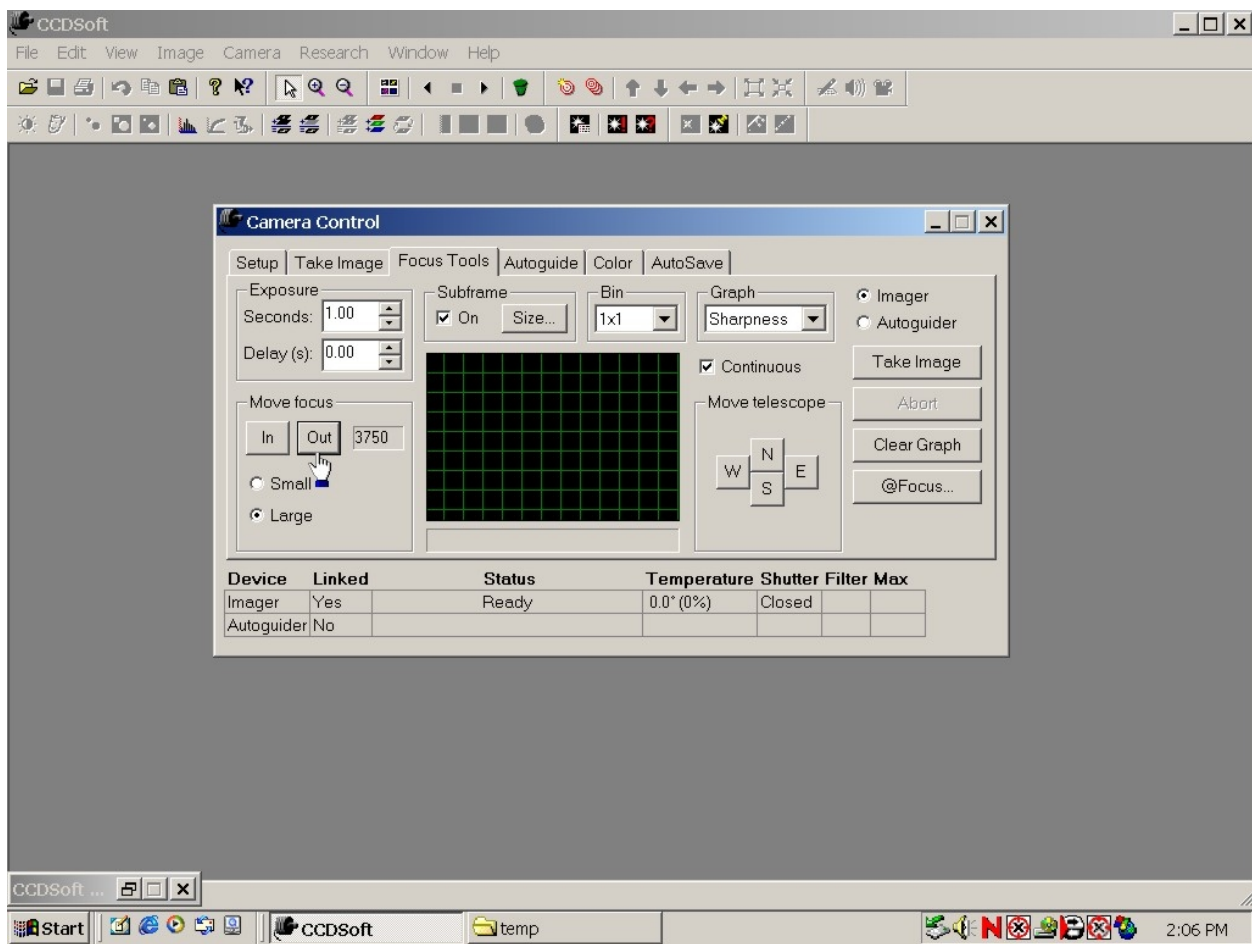

CCDSoft now implements the “Sleep” and “Wake-Up” features of the TCF-S. Both are available in the TCF-S Settings dialog box. Sleep is a low-power mode which allows a remote user to “power-down” the focuser without turning it completely off. This option allows a convenient remote startup.

* CCDSoft Version 5 and @Focus are copyright Software Bisque and Santa Barbara Instrument Group. @Focus uses sharpness technology developed by Björn Heijligers

Appendix E

TCF-S/TCF-S3 CONTROLLER SOFTWARE

The TCF-S/TCF-S3 Controller software program offers the user complete control of all programmable features of the TCF-S/TCF-S3 focuser. In addition, various operating variables such as the temperature coefficients can be changed. The display window of the operating program is small and can be placed in an unused area of your PC's desktop.

To install the TCF-S/TCF-S3 Controller program on your WIN95/98/2000, WIN NT, Windows ME, or Windows XP operating system, run the setup program. The latest version of the TCF-S/TCF-S3 Controller software package is available for free download from:

www.optecinc.com

Uninstall any previous version of the program before installing a new one. Make sure that any anti-virus programs are turned off. Download the file to your desktop and then run it. The program files are copied to a folder under OPTEC in the Program Files directory. You can delete or save the setup program at your option after installation.

To start the program, double-click the TCF-S/TCF-S3 Controller icon in the Optec program group under the start menu. The default serial port for the TCF-S/TCF-S3 Controller is COM 0 which means that the program will not connect until you set a valid COM port. COM ports 1 through 9 are acceptable.

The HELP file available from the start menu or from within the TCF-S/TCF-S3 control program has more information concerning startup and operation.

Appendix F

REMOTE KEYPAD



The plastic control box for the TCF-S focuser was never intended for frequent use at the telescope using it in a manual operating mode. The intended use was for complete computer operation with the control box located in some safe area near the computer. With three cables going to the control box, it was difficult to use as a hand paddle in any case.

To allow manual control of the TCF-S/TCF-S3 at the telescope, a remote keypad with IN and OUT pushbuttons is available as an option. The all aluminum device comes with a 3-foot cable (other lengths are optional) which plugs into the temperature probe connector located on the focuser. Neither the serial control or auto temperature compensation modes of the TCF-S focuser are operational when the remote keypad is in use. This keypad accessory is for manual hand operation of the focuser only. The connection is hot swappable so that the temperature probe can be plugged back in and normal TCF-S/TCF-S3 operation resumed at any time without a reboot.

The remote keypad measures 1 x 1 x 6 inches and has two pushbuttons for IN and OUT functions. A stainless steel hook allows the unit to be stored by hanging on any available handle such as the hand hold on many Meade telescopes. Identified by stock number 17680. Requires firmware version 2.30 and above in the control box. Receives power from the focuser so batteries are not necessary